

50Hz



BZ Stainless steel standard pump
BZ Bomba normalizada en acero inoxidable
BZ Pompe standard en acier inoxydable

BTS
ENGINEERING

<https://prom-nasos.pro>
<https://bts.net.ua>
<https://prom-nasos.com.ua>

+38 095 656-37-57,
+38 067 360-71-01,
+38 063 362-12-31,
info@prom-nasos.pro

<https://bts.net.ua>



BZ
Stainless steel standard pump
Bomba normalizada en acero inoxidable
Pompe standard en acier inoxydable



NEW/NUEVO/NOUVEAU

DESCRIPTION/DESCRIPCIONES/DESCRIPTION

- ◆ Stainless steel 304 standard pump design
 - ◆ All wetted parts are in stainless steel 304
 - ◆ Both square motor & round motor available
 - ◆ Stainless steel AISI 316 material as request
 - ◆ Back pull-out design without removing the pipes
 - ◆ Quality NSK bearing, wear resistance mechanical seal
 - ◆ Available to delivery some impure liquid
- ◆ Diseño de bomba estándar de acero inoxidable 304
 - ◆ Todas las partes húmedas son de acero inoxidable 304.
 - ◆ Motor cuadrado y motor redondo disponibles.
 - ◆ Material de acero inoxidable 316 según pedido
 - ◆ Diseño de extracción posterior sin quitar las tuberías
 - ◆ Rodamiento de marca NSK y cierre mecánico personalizado
 - ◆ Disponible para la entrega de algún líquido impuro
- ◆ Conception de pompe standard en acier inoxydable 304
 - ◆ Toutes les pièces en contact avec le fluide sont en inox304
 - ◆ Moteur carré et moteur rond disponibles
 - ◆ Matériau en acier inoxydable 316 comme demande
 - ◆ Conception arrière coulissante sans retirer les tuyaux
 - ◆ Roulement NSK qualité, joint mécanique de résistance à l'usure
 - ◆ Disponible pour la livraison de liquide impur

USING LIMITS/LÍMITES UTILIZACIÓN/UTILISATION LIMITES

- ◆ Liquid temperature between -10°C and +120°C
 - ◆ Ambient temperature between 0°C and +50°C
 - ◆ Max. working pressure **16 bar/Continuous S1**
- ◆ Temperatura del líquido de -10 °C hasta +120 °C
 - ◆ Temperatura ambiente de 0 °C hasta +50 °C
 - ◆ Presión máxima **16 bar/Continuo S1**
- ◆ Température du liquide entre -10 °C et +120 °C
 - ◆ Température ambiante entre 0 °C et +50 °C
 - ◆ Max. pression de service **16 bar/Continu S1**

MODEL CODE/CÓDIGO MODELO/CODE MODÈLE

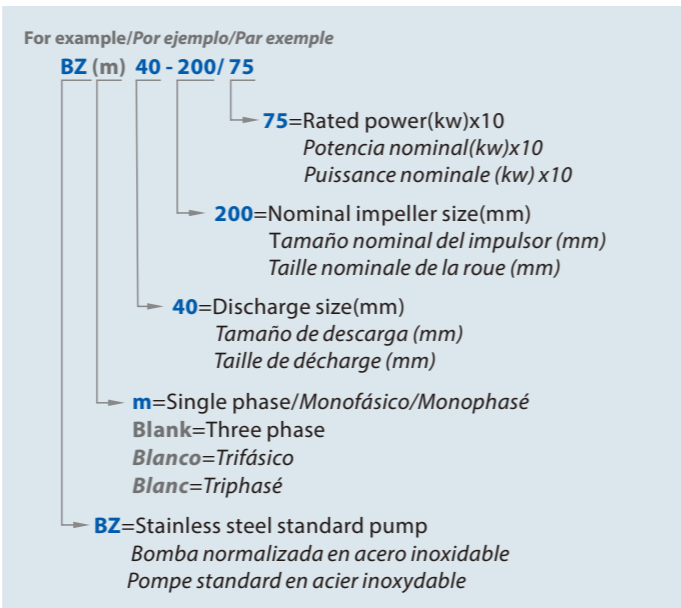

MODEL MODELO MODÈLE	DN mm	Power Potencia Puissance		Q=DELIVERY/CAUDAL/DÉBIT																									
		kw	hp	l/min	150	200	300	333	400	600	700	900	1200	1900	2100	2200	2300	2500	3400	3600	3800	4000							
				m³/h	9	12	18	20	24	36	42	54	72	114	126	132	138	150	204	216	228	240							
H=Head/Altura/Hauteur(m)																													
BZ 32-160/11	50x32	1.1	1.5	22.5	19.9	18.4	14.1	12	-	-	-	-	-	-	-	-	-	-	-	-	-	-	-	-	-	-	-	-	-
BZ 32-160/15	50x32	1.5	2	29.5	26.5	24.5	19.2	17	-	-	-	-	-	-	-	-	-	-	-	-	-	-	-	-	-	-	-	-	-
BZ 32-160/22	50x32	2.2	3	37	34	32	27	25	-	-	-	-	-	-	-	-	-	-	-	-	-	-	-	-	-	-	-	-	-
BZ 32-200/30	50x32	3	4	44	40	37.5	31	28	-	-	-	-	-	-	-	-	-	-	-	-	-	-	-	-	-	-	-	-	-
BZ 32-200/40	50x32	4	5.5	55	52	49.5	43.5	40.5	37	-	-	-	-	-	-	-	-	-	-	-	-	-	-	-	-	-	-	-	-
BZ 32-200/55	50x32	5.5	7.5	70.5	67.5	65	58.5	55	51	-	-	-	-	-	-	-	-	-	-	-	-	-	-	-	-	-	-	-	-
BZ 40-125/15	65x40	1.5	2	20	-	19	17.6	17	15.7	10.3	7	-	-	-	-	-	-	-	-	-	-	-	-	-	-	-	-	-	-
BZ 40-125/22	65x40	2.2	3	26.5	-	25.5	24	23.5	22	16.4	13	-	-	-	-	-	-	-	-	-	-	-	-	-	-	-	-	-	-
BZ 40-160/30	65x40	3	4	31	-	29.5	27.5	27	25.5	20	17	-	-	-	-	-	-	-	-	-	-	-	-	-	-	-	-	-	-
BZ 40-160/40	65x40	4	5.5	40	-	38.5	37	36	34.5	29	25.5	-	-	-	-	-	-	-	-	-	-	-	-	-	-	-	-	-	-
BZ 40-200/55	65x40	5.5	7.5	47	-	45.5	44	43	41	35	31	-	-	-	-	-	-	-	-	-	-	-	-	-	-	-	-	-	-
BZ 40-200/75	65x40	7.5	10	58	-	57	55.5	55	53.5	47.5	44	-	-	-	-	-	-	-	-	-	-	-	-	-	-	-	-	-	-
BZ 40-200/110	65x40	11	15	72	-	71	70	70	68.5	63	59	-	-	-	-	-	-	-	-	-	-	-	-	-	-	-	-	-	-
BZ 50-125/22	65x50	2.2	3	19	-	-	-	-	17.5	14.9	13.4	10.7	-	-	-	-	-	-	-	-	-	-	-	-	-	-	-	-	-
BZ 50-125/30	65x50	3	4	22	-	-	-	-	20.5	18.4	17	14.4	8	-	-	-	-	-	-	-	-	-	-	-	-	-	-	-	-
BZ 50-125/40	65x50	4	5.5	26.5	-	-	-	-	26	24	22.5	20.5	14	-	-	-	-	-	-	-	-	-	-	-	-	-	-	-	-
BZ 50-160/55	65x50	5.5	7.5	33	-	-	-	-	31	28.5	27	24.5	18	-	-	-	-	-	-	-	-	-	-	-	-	-	-	-	-
BZ 50-160/75	65x50	7.5	10	40	-	-	-	-	38.5	36	35	32.5	26	-	-	-	-	-	-	-	-	-	-	-	-	-	-	-	-
BZ 50-200/92	65x50	9.2	12.5	53	-	-	-	-	-	49	47.5	44.5	34	-	-	-	-	-	-	-	-	-	-	-	-	-	-	-	-
BZ 50-200/110	65x50	11	15	59	-	-	-	-	-	55	54	51	42	-	-	-	-	-	-	-	-	-	-	-	-	-	-	-	-
BZ 50-200/150	65x50	15	20	72	-	-	-	-	-	69	68	65	57	-	-	-	-	-	-	-	-	-	-	-	-	-	-	-	-
BZ 65-125/40	80x65	4	5.5	22.2	-	-	-	-	-	19.8	19	17.3	13.5	6.3	-	-	-	-	-	-	-	-	-	-	-	-	-	-	-
BZ 65-125/55	80x65	5.5	7.5	27	-	-	-	-	-	-	24	22.2	18.5	10.8	8	-	-	-	-	-	-	-	-	-	-	-	-	-	-
BZ 65-125/75	80x65	7.5	10	32	-	-	-	-	-	-	29.5	27.8	24	16.1	13.4	12	-	-	-	-	-	-	-	-	-	-	-	-	-
BZ 65-160/92	80x65	9.2	12.5	36.5	-	-	-	-	-	-	34.5	32.8	29	21.1	18.3	16.8	-	-	-	-	-	-	-	-	-	-	-	-	-
BZ 65-160/110	80x65	11	15	40.5	-	-	-	-	-	-	38.5	37.1	33.5	25.8	23	21.5	20	-	-	-	-	-	-	-	-	-	-	-	-
BZ 65-160/150	80x65	15	20	48	-	-	-	-	-	-	45.5	44	40.5	32.6	29.6	28	26.5	-	-	-	-	-	-	-	-	-	-	-	-
BZ 65-200/150	80x65	15	20	53.5	-	-	-	-	-	-	51	49	44.5	35.3	31.8	30	-	-	-	-	-	-	-	-	-	-	-	-	-
BZ 65-200/185	80x65	18.5	25	60.5	-	-	-	-	-	-	58.5	56.5	52	43	39.7	38	36.3	-	-	-	-	-	-	-	-	-	-	-	-
BZ 65-200/220	80x65	22	30	67	-	-	-	-	-	-	65.5	64	60	51	48	46.5	45	-	-	-	-	-	-	-	-	-	-	-	-
BZ 80-160/110	100x80	11	15	29	-	-	-	-	-	-	-	-	-	27.5	24.2	23	22.4	21.8	20.4	12.5	-	-	-	-	-	-	-	-	-
BZ 80-160/150	100x80	15	20	35	-	-	-	-	-	-	-	-	-	-	34.5	31.5	30.5	30	29.4	28.1	21	19.1	17	-	-	-	-	-	-
BZ 80-160/185	100x80	18.5	25	40	-	-	-	-	-	-	-	-	-	-	39.5	36.7	35.7	35.2	34.7	33.5	26.4	24.4	22.3	20	-	-	-	-	-
BZ 80-200/220	100x80	22	30	50	-	-	-	-	-	-	-	-	-	-	48.5	44.5	43	42	41	39	27.8	25	-	-	-	-	-	-	-
BZ 80-200/300	100x80	30	40	60	-	-	-	-	-	-	-	-	-	-	59	56	54.5	54	53	51	41.5	39	36.1	33	-	-	-	-	-
BZ 80-200/370	100x80	37	50	66	-	-	-	-	-	-	-	-	-	-	64	61	59.5	59	58	56.5	47	44.5	41.5	38.5	-	-	-	-	-

PERFORMANCE CURVE/CURVA DE RENDIMIENTO/COURBE DE PERFORMANCE

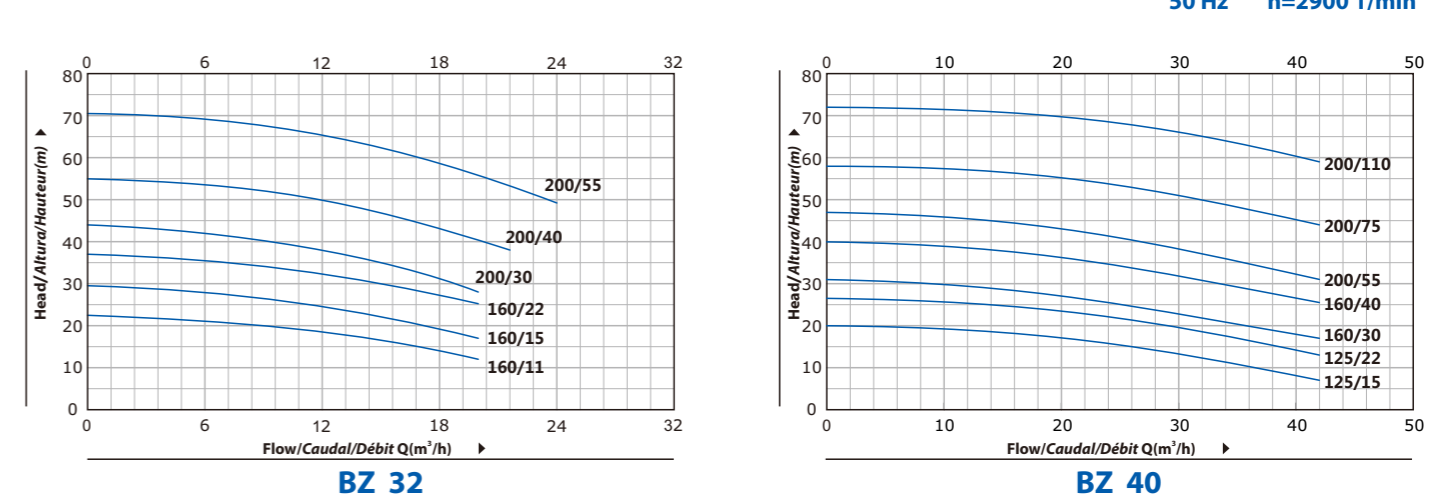

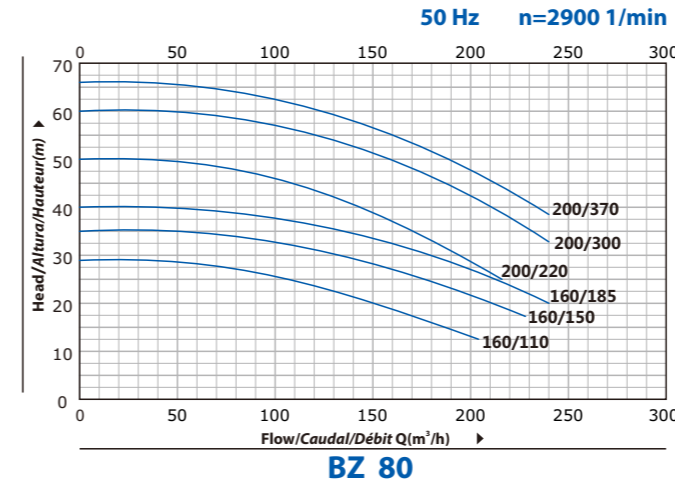
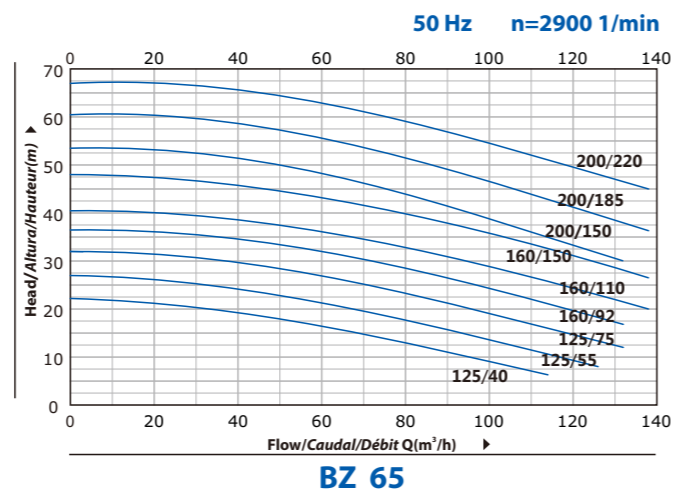
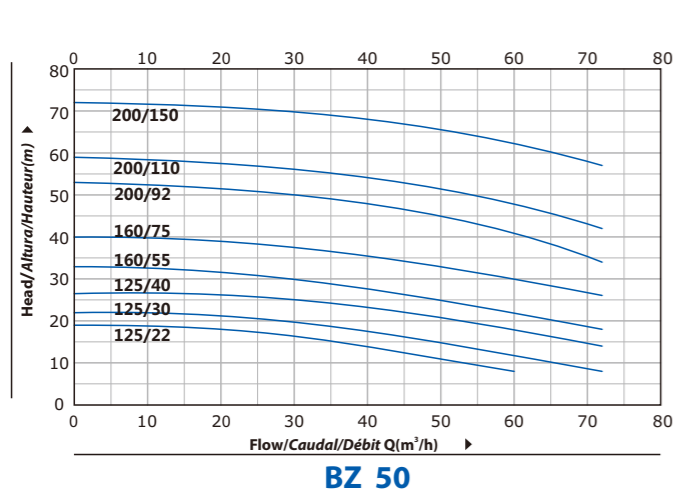

Back pull-out design
Diseño extraíble hacia atrás
Conception arrière coulissante

It allows removal of the motor, the coupling, the cantilever support and the impeller without compromising the housing of the pump body or removing the pipes.

Permite retirar el motor, el acoplamiento, el soporte en voladizo y el impulsor sin comprometer la carcasa del cuerpo de la bomba ni quitar las tuberías.

Il permet le démontage du moteur, de l'accouplement, du support en porte-à-faux et de la roue sans compromettre le logement du corps de pompe ou retirer les tuyaux.

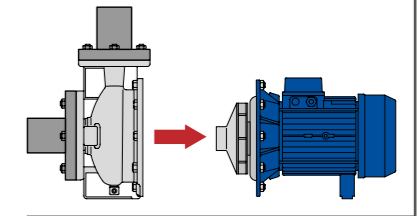

MATERIAL DESCRIPTION/DESCRIPCIÓN DE MATERIAL/DESCRIPTION DU MATÉRIEL

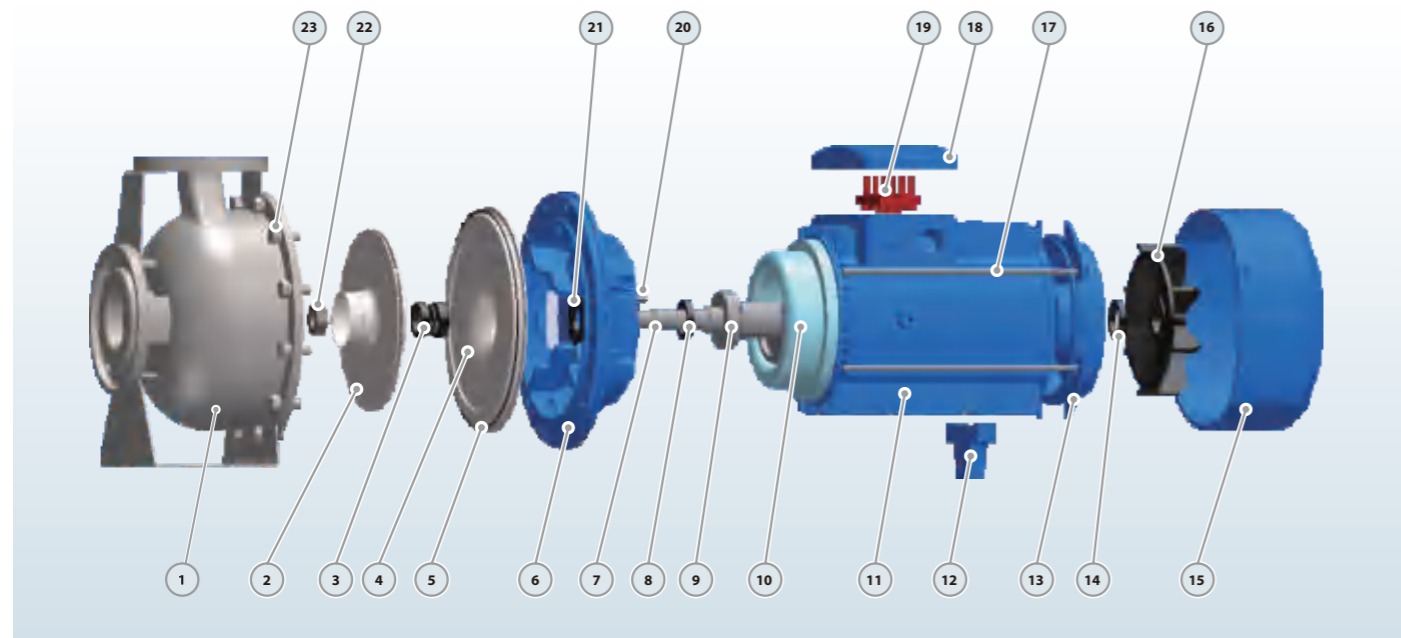

No.	Description Descripción Description	Material Material Matériel	No.	Description Descripción Description	Material Material Matériel	No.	Description Descripción Description	Material Material Matériel
1	Pump Case Cuerpo de Bomba Boîtier de pompe	SS304 Inox 304 Inox 304	9	Bearing Rodamiento Palier	Ball Bearing Bola Rodamiento Palier Balle	17	Through Bolt Perno Boulon	Steel Acero Acier
2	Impeller Impulsor Roue	SS304 Inox 304 Inox 304	10	Wound Stator/Rotor Estator/Rotor Stator/Rotor	Silicon/Copper Silicio/Cobre Silicium/Cuivre	18	Terminal Box Caja Bornas Boîte Bornes	Aluminum Aluminio Aluminium
3	Mechanical Seal Cierre Mecánico Sceller	SiC/Carbon/SS304 SiC/Grafito/Inox304 SiC/Carbon/Inox304	11	Motor Case Cuerpo Motor Boîtier Moteur	Aluminum Aluminio Aluminium	19	Terminal Board Tablero Bornas Bornier	Plastic Plástico Plastique
4	Baffle plate Placa de baffle Plaque chicane	SS304 Inox 304 Inox 304	12	Support Foot Soporte Pie Pied support	Plastic Plástico Plastique	20	Impeller Key Chaveta Clé	Iron Hierro Le fer
5	O-ring Junta Tórica Joint Torique	Rubber Caucho Caoutchouc	13	Back Cover Tapa Trasera Capot Arrière	Cast iron Fundición Fonte	21	Water Deflector Deflector Déflecteur	Rubber Caucho Caoutchouc
6	Connection Conexión Lien	Cast iron Fundición Fonte	14	Reinforced Seal Sello Reforzado Sceller	Rubber Caucho Caoutchouc	22	Impeller Nut Nuez Noix	Galvanized Steel Acero Galvanizado Acier Galvanisé
7	Shaft Eje Arbre	SS304 Inox 304 Inox 304	15	Fan Cover Tapa Capot	Aluminum Aluminio Aluminium	23	Connection Bolt Perno Boulon de connexion	Steel Acero Acier
8	Reinforced Seal Sello Reforzado Sceller	Rubber Caucho Caoutchouc	16	Fan Ventilador Ventilateur	Plastic Plástico Plastique			

DIMENSIONS AND WEIGHT/DIMENSIONES Y PESOS/DIMENSIONS ET POIDS

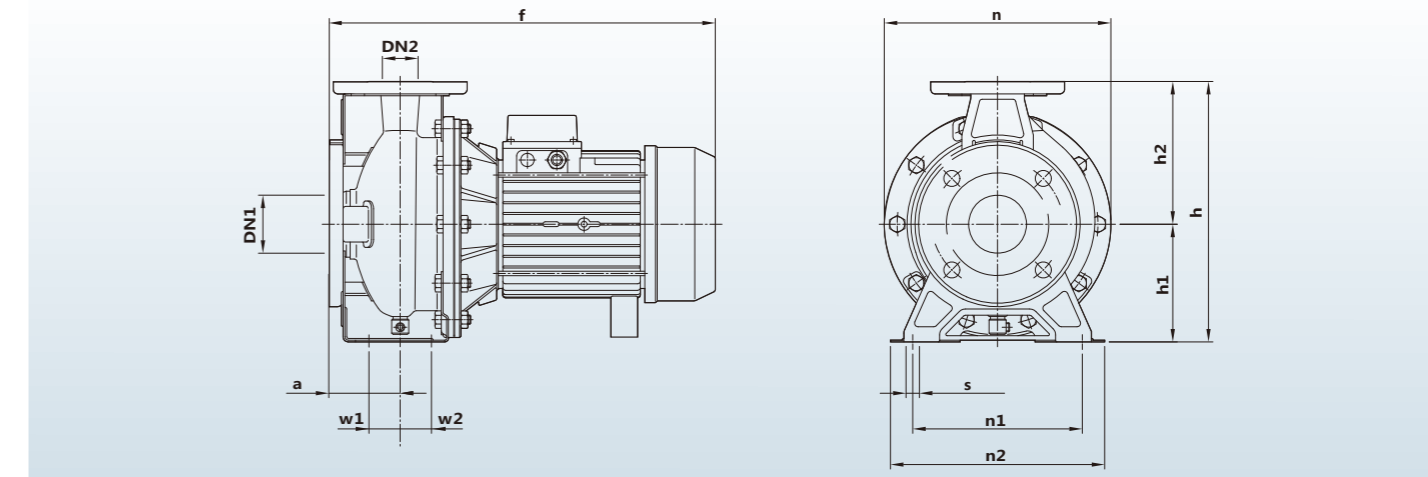

MODEL/MODELO/MODÈLE		DIMENSIONS/DIMENSIONES/DIMENSIONS mm											kg			
Single-phase Monofásico Monophasé	Three-phase Trifásico Triphasé	DN1	DN2	a	f	h	h1	h2	n	n1	n2	w1	w2	s	1~	3~
32-160/11-15	32-160/11-15	50	32	100	493	306	150	156	235	148	175	60	31	15	20.6/23.5	19.6/22.5
32-160/22	32-160/22	50	32	100	493	306	150	156	235	148	175	60	31	15	25.6	24.6
32-200/30	32-200/30-40	50	32	100	538	306	150	156	235	148	175	60	31	15	33.8	32.8/39.5
-	32-200/55	50	32	100	538	306	150	156	235	148	175	60	31	15	-	48.5
40-125/15-22	40-125/15-22	65	40	100	493	306	150	156	235	148	175	60	31	15	21.1/23.7	20.1/22.7
40-160/30	40-160/30-40	65	40	105	542	340	160	180	278	148	175	60	31	15	29	28/35.1
-	40-200/55-75	65	40	105	584	340	160	180	278	148	175	60	31	15	-	48.8/56.2
-	40-200/110	65	40	105	650	340	160	180	235	148	175	60	31	15	-	67.5
50-125/22	50-125/22	65	50	100	428	340	160	180	235	148	175	60	31	15	29.1	28.1
50-125/30	50-125/30-40	65	50	100	493	340	160	180	278	148	175	60	31	15	29.6	28.6/35.2
-	50-160/55-75	65	50	105	584	340	160	180	278	148	175	60	31	15	-	49.1/55.5
-	50-200/92-110	65	50	105	650	365	185	180	278	148	175	60	31	15	-	61.7/67.5
-	50-200/150	65	50	105	768	365	185	180	278	148	175	60	31	15	-	96
-	65-125/40	80	65	100	584	340	160	180	278	148	175	60	31	15	-	40
-	65-125/55-75	80	65	100	584	340	160	180	278	148	175	60	31	15	-	52/58.5
-	65-160/92-110	80	65	113	675	345	160	185	278	148	175	60	31	15	-	67/75.6
-	65-160/150	80	65	113	732	345	160	185	278	148	175	60	31	15	-	93
-	65-200/150-185	80	65	113	793	370	185	185	278	148	175	60	31	15	-	114/127
-	65-200/220	80	65	113	793	370	185	185	278	148	175	60	31	15	-	136
-	80-160/110	100	80	125	700	400	180	220	278	148	175	60	31	15	-	85
-	80-160/150-185	100	80	125	870	400	180	220	278	148	175	60	31	15	-	119/135
-	80-200/220	100	80	125	915	450	200	250	278	148	175	60	31	15	-	185
-	80-200/300-370	100	80	125	985	450	200	250	278	148	175	60	31	15	-	265/285