



QEEHUA[®]

CHEMICAL PUMP & FILTER
WITH ACID-ALKALI RESISTANCE
EXPERT IN R&D AND MANUFACTURING

BTS
ENGINEERING

<https://prom-nasos.pro>

<https://bts.net.ua>

<https://prom-nasos.com.ua>

+38 095 656-37-57

+38 067 360-71-01

+38 063 362-12-31

info@prom-nasos.pro

Manual

Magnetic Pump

Model: MD, QHX



CONTENS

Thank you for choosing our company's MD and QHX series magnetic drive pumps. In order to ensure the safe, long-term, and correct operation of the pump, maximize the pump's effectiveness, and extend the life of the pump, please read this manual carefully.

I、Product Introduction	02
1.Work principle	02
2.Model introduction	02
3.Pump characteristics	03
II、 Safety use of the pump	04
1.Safety warning	04
2.Important tips for safe use	04
III、 Pump installation	05
IV、 Pump maintenance	05
V、 Operation instruction	06
VI、 Debugging	08
VII、 Performance specification	11

I、Introduction of MD, QHX series magnetic pump

1、Work principle

Each series of MD / QHX magnetic pump is a kind of centrifugal magnetic drive pump which is developed by applying the principle of magnetic mechanics to adapt to various applications. The impeller in the pump cavity rotates under the action of magnetic force, which transports liquid from the inlet to the outlet. This series of magnetic pump has small volume, large torque, small eddy current, high transmission efficiency, good corrosion resistance, durability and safety, and can be used as a pump for various chemical industry processes. Most chemical liquids can be pumped with this pump. It is a kind of best industrial environmental protection equipment for preventing pollution and ensuring environmental purification in contemporary times. Its performance reaches the advanced level of similar products at home and abroad.

2、Model specification

(1) MD series

MD- F- 25- 8- S- A- V- 6- V38

① ② ③ ④ ⑤ ⑥ ⑦ ⑧ ⑨

①. **Model number:** MD

②. **Pump material:**

F-GFRPP C-CFRPP P-PVDF E-CFRETFE

③. **Inlet and outlet diameter:**

20-3/4" 25-1"

④. **Horsepower:**

0-0.008HP 1-0.013HP 2-0.027HP 3-0.06HP 4-0.09HP 5-0.12HP
7-0.24HP 8-0.35HP

⑤. **Inlet and outlet connection:**

S-SCREW H-HOSE

⑥. **Spindle materials:**

A-CERAMIC S-SSIC

⑦. **Rubber material:**

E-EPDM V-VITON

⑧. **Frequency:**

5-50HZ 6-60HZ

⑨. **Voltage:**

V11-1Ø/110V、 V22-1Ø/220V/240V、 V38-3Ø/220V/380V、 V41-3Ø/280V/415V

(2) QHX series

QHX- F - 44 - 0 - C - C - V - 6 - V38- A

① ② ③ ④ ⑤ ⑥ ⑦ ⑧ ⑨ ⑩

①.**Model number:** QHX

②.**Pump material:**

F-GFRPP C-CFRPP P-PVDF E-CFRETFE

③.**Inlet and outlet diameter:**

25-25x25mm 44-40x40mm 54-40x50mm 65-50x65mm

④.**Horsepower:**

0-1/2HP 1-1HP 2-2HP 3-3HP 5-5HP

⑤.**Spindle materials:**

C-CERAMIC S-SSIC

⑥.**Bearing material:**

C-CARBON S-SSIC P-PTFE

⑦.**Rubber material:**

E-EPDM V-VITON

⑧.**Frequency:**

5-50HZ 6-60HZ

⑨.**Voltage:**

V38-3Ø/220V/380V V41-3Ø/280V/415V V44-3Ø/240V/440V

⑩.**Specific Gravity:**

50HZ→A-1.2 B-1.5 C-2.0 60HZ→ D-1.2 E-1.5 F-2.0

3、 Pump characteristic

- (1)、Magnetic drive, no shaft seal design, completely leak-proof;
- (2)、Anti-idling performance;
- (3)、Applicable to the circulation of various chemical liquids;
- (4)、The pump adaptation temperature depends on the properties of various chemical solutions. GFPP / CFRPP - 80°C or lower, PVDF - 100°C or lower, CFRETFE - 150°C or lower.
- (5)、Easy assembly: The internal parts are standardized and the structure is exquisite, which can be easily disassembled and replaced.
- (6)、Wide range of applications: Qihua magnetic pumps have a complete range of products, and users can choose according to their needs, which can meet the needs of high flow / low head or low flow / high head.

II、Basic principles of safe operation

1、Safety warning!

- ①、 Working without power off can cause electric shock!
- ②、 It is forbidden to start the pump without connecting the ground wire and the leakage protector!
- ③、 Electrical work should be performed by qualified personnel!
- ④、 When operating the pump, please wear protective equipment to prevent serious injury from chemical liquid!
- ⑤、 Poisoning may occur when working with toxic liquids!
- ⑥、 Use the pump strictly in accordance with its instructions and scope of use!
- ⑦、 When the pump is running, the surface temperature of the motor and the pump will be very high. Do not touch it directly!
- ⑧、 It is forbidden to modify the pump without authorization, otherwise it will lead to serious accidents. Besides, the company is not responsible for the losses caused by users who modify the pump without permission or in no accordance with the operating specifications!
- ⑨、 The magnetic drive pump contains a strong magnet, and its strong magnetic field will cause obvious damage to people wearing electronic devices such as electronic pacemakers!

2、Important note!

- ①、 Prohibit the idle-running of pump. The idling will cause friction of parts inside the pump to generate heat, which will damage the pump. (Making the pump work with the intake valve fully closed is also considered idle-running).
- ②、 During the operation, when danger signals and abnormal conditions are found, the operation shall be terminated immediately, and the abnormalities shall be eliminated and then the pump shall be restarted.
- ③、 Arrange qualified operators to operate and use the pump.
- ④、 Only use the pump at the specified voltage. Failure to do so will result in damage to the pump or fire.
- ⑤、 There should be protective measures against liquid splashing or leakage in place.
- ⑥、 Poisoning may occur when working with toxic liquids. Adequate ventilation at the place of operation must be ensured.
- ⑦、 Do not scratch, damage, squeeze, or stretch the cable with force. Using damaged cables can cause fire or electric shock.
- ⑧、 Covered pumps are prone to fire or mechanical failure due to internal heat build-up.
- ⑨、 When someone is performing maintenance on the pump, pay attention to avoid other operators turning on the power switch due to mistakes. It is best to place a warning sign next to the power switch to inform someone that the pump is being repaired.
- ⑩、 The liquid flowing out of the pump, some of which are highly toxic and hazardous chemical liquids, must be directed to special containers for storage.

III、 Pump installation

- 1、 Installation location: The ambient temperature of the installation site should be 0-40 ° C, and the relative humidity should be below 90%. Please select a place that is flat and will not be vibrated by other machines. Consider leaving enough space for maintenance.
- 2、 Fixation of the base: The base area of the fixed pump must be larger than the base area of the pump. If the fixing area is not large enough, the base will be damaged due to the concentrated force. The pump base must be securely fixed.
- 3、 MD / QHX series pumps cannot be self-priming and should be installed in a positive pressure. The distance from the liquid surface to the suction port should be more than 30cm. If the distance is too short, it is easy to suck in air and cause abnormal wear of the pump bearings.
- 4、 Direction of the pump outlet: The direction of the pump outlet can be arbitrarily arranged as required, but in order to exhaust the gas in the pump chamber, the outlet direction is recommended to be upward.
- 5、 The pump head depends on the property and temperature of the liquid, and the length of the suction pipe. Keep the length of the pipeline as short as possible and reduce detours.
- 6、 The inlet and outlet valves should be installed near the inlet and outlet.
- 7、 Check the voltage on the nameplate before wiring. Please use special wiring materials and be sure to install a ground wire.
- 8、 The pump should be installed as close to the tank as possible and lower than the tank (self-flowing liquid). If the pump is installed above the liquid level in the tank (suction type), a foot valve must be installed on the tank liquid line and the suction pipe.
- 9、 When the pump is used to transport hazardous liquids, flushing lines should be installed so that the inside of the pump can be cleaned when the pump is disassembled.

IV、 Pump maintenance and service.

- 1、 Handle the pump carefully: Dropping or hitting the ground could damage the pump or affect its performance.
- 2、 Liquid filling: The pump must be filled with liquid before the pump runs. Idle-running can cause damage to pump parts.
- 3、 The liquid temperature range is 0-80 ° C.
- 4、 Due to the strong magnetic field in the pump body, it cannot be used to transport liquids containing magnetic materials, such as iron and nickel.
- 5、 The relative humidity should be below 90%. Take care to prevent dust and water from entering the motor. Do not splash liquid on the motor, otherwise short circuit or fire may be caused.
- 6、 The screws will loosen after a period of use of the pump. Check and tighten normally, taking care not to damage the plastic front case.
- 7、 Always check the pump for unusual vibrations or noise. Check both motor current and pump outlet flow. If an abnormal situation is found, the power should be cut off quickly to find out the cause and eliminate it.
- 8、 If foreign matter enters the pump, immediately cut off the power and remove the blockage. Using the pump with foreign matter in the pump may cause damage or malfunction of the pump.

V、 Operation instruction

- 1、 Before using the pump, make sure that the inlet and outlet hoses are securely connected.
- 2、 Dry running (no liquid in the pump) can damage the pump. Make sure that it is filled with liquid before use.
- 3、 Do not run the pump with the inlet / outlet valve completely closed or almost completely closed.

Please do not suddenly open or close the inlet valve or outlet valve, otherwise the magnetic capsule will come off and the impeller cannot rotate normally. (In this case, the power should be disconnected immediately. When the motor stops, the magnetic coupling will be connected automatically). After the pump is mounted and the pipes and lines are connected, follow the steps below to operate the pump.

No.	Operating steps	Program
1	close or open the valve	open the suction valve totally
		open the discharge valve totally
2	Fill the pump with liquid	Make sure the pump is filled with liquid, and completely close the discharge valve when it is completely filled with liquid.
3	Check if the steering of the motor is correct.	Then check the rotation of the motor and perform jog operation to make the pump rotate. (The correct direction of motor rotation is the direction of the arrow on the pump. Check the direction of the fan with the eyes through the motor fan cover.)
	Close the switch and immediately cut off the switch. (Less than 1 second)	After disconnecting the power switch, carefully observe and confirm whether the fan of the motor stops slowly and smoothly.
4	Turn on the power to make the pump work. Next, adjust the discharge flow rate of the discharge pressure.	If the fan of the motor does not stop slowly and smoothly, the inside of the motor may be stuck.
		Open the valve carefully and pay attention to the indication of the ammeter to prevent overload of the motor and prevent the valve from being opened excessively.
		Open the discharge valve gradually within 1 minute, and adjust the discharge pressure while checking the indication on the discharge side pressure gauge. (Also check the output value of the pressure gauge on the discharge side and adjust the discharge volume.) Note: After the pump is running normally and it is confirmed that the total head is increased to the pressure when it is closed, gradually open the discharge valve for flow setting.

Attachment: internal section

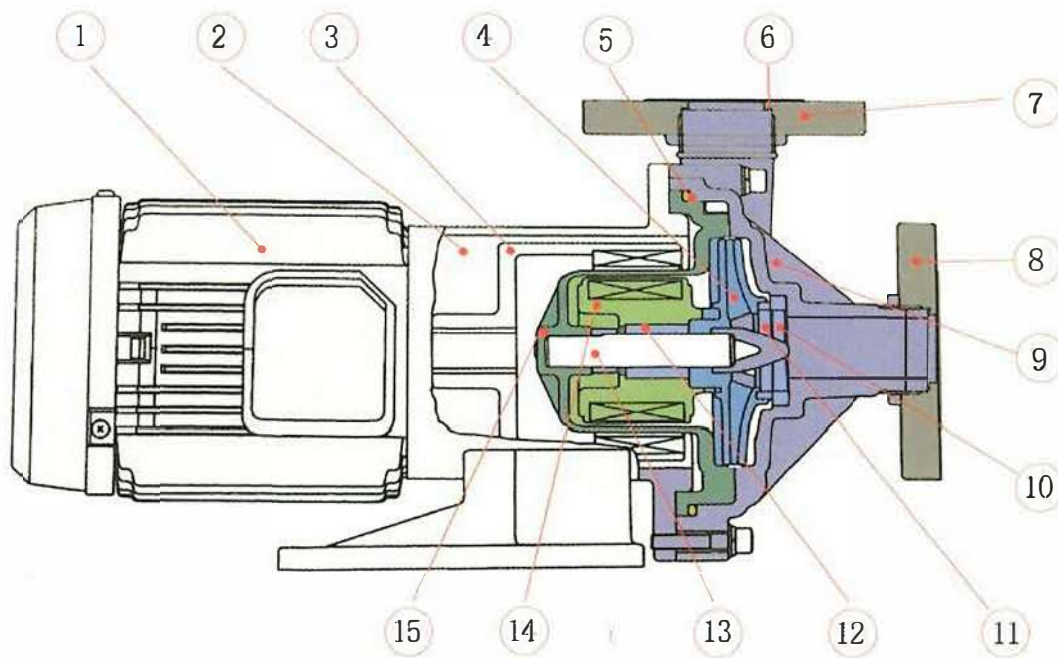

- | | | | | |
|----------------------|-----------------|----------------|-------------------|------------------------|
| 1.motor | 2.baseplate | 3.drive magnet | 4.impeller | 5. Sealed o ring |
| 6.sealed o ring | 7.outlet flange | 8.inlet flange | 9.front cover | 10.wear-resisting ring |
| 11.front thrust ring | 12.bearing | 13.spindle | 14.passive magnet | 15.back cover |

VI 、 Debugging

If a fault occurs during operation, immediately cut off the power and refer to the following table for troubleshooting.

Fault	Pump symptoms		Reason	Inspection and measures
	Discharge valve closed	Discharge valve opened		
		The value showed by the pressure gauge and vacuum gauge is zero	Insufficient irrigation, dry running	Stop the pump, fill it with liquid, and restart the pump.
No liquid transporting	The liquid drops immediately when it is filled		Foot valve blocked by foreign body.	Remove foreign matter from the foot valve. Check that the valve seat is not blocked by foreign objects.
	After starting, the pressure drops when the discharge valve opens	The hands of the pressure gauge and vacuum gauge swing and quickly point to zero	Air enters through suction pipe or flange gasket.	Check the air tightness of the flange connection on the suction line again. Check whether the suction level is low.
			The magnetic coupling is not connected properly	Stop the pump and use a screwdriver to check whether the motor fan is easy and stable to measure the current to check whether the overload occurs. Check if there is any foreign matter between the impeller and the casing; Check if the voltage is normal.

Fault	Pump symptoms		Reason	Inspection and measures
	Discharge valve closed	Discharge valve opened		
No liquid transporting	Pressure gauge does not increase		The speed of the pump is too low. Pump reverse rotation	Check the wiring and motor, and repair and replace the wiring position..
Too small discharge volume		The indication of the vacuum gauge is very large	The filter is blocked by foreign objects and the flow of liquid is blocked	Remove foreign objects from the filter
	Pressure gauge and vacuum gauge pointers are normal	The indication of the vacuum gauge is very high	Air bubbles in the suction tube	Check the installation of the suction pipe and correct it if necessary.
			Impeller inlet blocked	Partial disassembly to remove foreign objects.
		Pressure gauge and vacuum gauge values fluctuate	Air enters through suction pipe or flange gasket	Check the air tightness of the connection on the suction line and tighten if necessary.
			The discharge side of the pump is blocked by a foreign object	Remove foreign matter in the pump, remove foreign matter, or remove dirt in the pipeline.
	The indication of the pressure gauge is too low, the indication of the vacuum gauge is abnormally low	The indication of the vacuum gauge is high, and the indication of the pressure gauge is normal. The indication of the pressure gauge is very high, and the indication of the vacuum gauge is normal.	Bubbles and obstructions in the suction line	Inspect the suction line for protruding parts and take necessary measures
			Bubbles and obstructions in the suction line	Check the actual head and head loss of the discharge pipe, and take necessary measures.
		The indications of pressure gauges and vacuum gauges are very low.	Motor rotates in reverse	Reverse wiring position

Fault	Pump symptoms		Reason	Inspection and measures
	Discharge valve closed	Discharge valve opened		
Motor overheat			Voltage is too low	Check that the voltage and frequency are appropriate and check the specific gravity and viscosity of the liquid
			Ambient temperature	Stop the pump and use a screwdriver to check whether the electric surface fan can rotate easily and smoothly. Improve ventilation
Sudden decrease in output		High indication of vacuum gauge	Foreign matter clogged the filter	Remove foreign matter
Pump vibrates abnormally			<p>Foundation damage</p> <p>Foundation bolts become loose;</p> <p>Suction tube is closed, cavitation is generated;</p> <p>Pump bearing is worn, magnetic capsules is dissolved or pump shafts damage;</p> <p>The dynamic balance of active magnetic gets worse, impeller or magnetic capsule and the fixed part are touching.</p> <p>Bearing wear of Motor.</p>	<p>re-install</p> <p>Tighten bolt</p> <p>Clean and eliminate cavitation</p> <p>Replace</p> <p>Troubleshoot</p> <p>Replace bearing or motor</p>

VII、Performance specification sheet

(MD-200 ~ MD-258)

Model		MD-200	MD-201	MD-202	MD-203
Specific gravity limit		1.1	1.1	1.1	1.1
Casing type caliber	Inlet(mm)	14	16	18	20
	Outlet(mm)	14	16	18	20
Outer teeth caliber	Inlet(inch)	/	3/4	3/4	3/4
	Outlet(inch)	/	3/4	3/4	3/4
Full flow	50Hz(L/min)	11	16	27	32
	60Hz(L/min)	12	19	31	38
Full head	50Hz(M)	1.5	2.4	3.1	3.8
	60Hz(M)	2.1	3.4	4.3	5.4
Standard output	50H(M-L/min)	1.0-4.8	1.5-7.0	2.0-14.0	2.5-16
	60H(M-L/min)	1.0-7.5	1.5-13	2.0-22.0	2.5-24
Horse power 50HZ/60HZ	Output power (w)	6	10	20	45
	Input power (w)	20	30	45	90
	Phase (∅)	1	1	1	1
weight	(Kg)	0.87	1.53	2.1	3.4

Model		MD-204	MD-255	MD-257	MD-258
Specific gravity limit		1.1	1.2	1.0	1.2
Casing type caliber	Inlet(mm)	20	26	26	26
	Outlet(mm)	20	26	26	26
Outer teeth caliber	Inlet(inch)	3/4	1	1	1
	Outlet(inch)	3/4	1	1	1
Full flow	50Hz(L/min)	45	60	86	120
	60Hz(L/min)	52	70	97	135
Full head	50Hz(M)	4.6	5.6	6.7	8.6
	60Hz(M)	6.5	8.2	9.7	11.9
Standard output	50H(M-L/min)	4-22	4-30	4-50	6.5-60
	60H(M-L/min)	4-34	4-45	4-72	9-70
Horse power 50HZ/60HZ	Output power (w)	65	90	150/180	255/265
	Input power (w)	90/130	130/170	210/300	245/365
	Phase (∅)	1	1or3	1or3	1or3
weight	(Kg)	4.3	5.6	5.5	6.8

QHX-250 ~ QHX-665

Model	Inlet and outlet piping (mm)	Max flow (L/min)		Max head (m)		Horse power (HP)	Weight (kg)
		50Hz	60Hz	50Hz	60Hz		
QHX-250	25/25	150	150	16.12	15.33	0.5	14.5
QHX-440	40/40	240	240	12.3	13.0	0.5	13.3
QHX-251	25/25	180	180	22.09	23.46	1	19.1
QHX-441	40/40	330	330	19.0	19.6	1	19.0
QHX-542	50/40	450	450	24.4	25.3	2	25.7
QHX-552	50/50						26.5
QHX-542H	50/40	250	150	27.6	30.6	2	25.7
QHX-552H	50/50						26.5
QHX-543	50/40	510	510	30.6	31.8	3	27.9
QHX-553	50/50						28.0
QHX-543H	50/40	300	250	34.2	36.6	3	27.9
QHX-553H	50/50						28.0
QHX-545	50/40	500	500	35.0	39.4	5	38.6
QHX-555	50/50						34.4
QHX-653	65/50	600	600	20.0	20.1	3	29.6
QHX-655	65/50	860	860	27.6	28.1	5	39
QHX-662	65/65	900	850	14	15	2	27.7
QHX-663	65/65	1050	1000	17	18	3	29.2
QHX-665	65/65	1230	1250	21	23	5	39.2